

Hamiltonian Limit of the 3D Zamolodchikov Model

R. J. Baxter^{1,2} and G. R. W. Quispel^{1,2}

Received July 14, 1989

A two-dimensional quantum Hamiltonian $\mathcal{H}_{N,M}$ commuting with the layer-to-layer transfer matrix of the three-dimensional Zamolodchikov model is derived. This Hamiltonian is defined on a lattice of $N \times M$ sites. The special cases $N \times 2$, $2 \times M$, and $3 \times M$ are studied.

KEY WORDS: Statistical mechanics; lattice models; transfer matrix; Hamiltonian.

1. INTRODUCTION

The feature underlying the solvability of many two-dimensional statistical mechanical models is the existence of a one-parameter family of commuting one-dimensional transfer matrices.⁽¹⁾ These transfer matrices are parametrized by a so-called spectral parameter. Often there is an associated commuting quantum Hamiltonian \mathcal{H}_N . This is an operator on a one-dimensional chain of N sites, and is the logarithmic derivative of the transfer matrix with respect to the spectral parameter, evaluated at a value of the spectral parameter where the transfer matrix has a particularly simple form, e.g., at a value where it is a simple shift operator. The Hamiltonian associated with the symmetric eight-vertex model, for example, is the Heisenberg or XYZ chain operator.

The only three-dimensional statistical mechanical model that has been solved to date using the method of commuting transfer matrices is the Zamolodchikov model.⁽²⁻⁶⁾ This model is a spin model on a simple cubic

This paper is dedicated to Cyril Domb.

¹ Mathematics Research Section, School of Mathematical Sciences, Australian National University, Canberra, ACT 2601, Australia.

² Department of Theoretical Physics, Research School of Physical Sciences, Australian National University, Canberra, ACT 2601, Australia.

lattice, whose interactions are determined by three parameters θ_1 , θ_2 , and θ_3 . One can think of these parameters as being associated with the vertical, left-to-right, and front-to-back directions, respectively. The model is symmetric under a permutation of the θ_i combined with the associated rotation of the lattice. In this paper we derive the Hamiltonian associated with the Zamolodchikov model. There are some differences from the above discussion. First of all, for fixed θ_1 , the *two*-dimensional transfer matrices $T[\theta_1, \theta_2, \theta_3]$ working in the vertical direction form a commuting family, parametrized by *two* spectral parameters θ_2 and θ_3 . For $\theta_2 = 0$ the transfer matrix is a simple shift operator, so we want to differentiate with respect to θ_2 at this point. This means that our resulting Hamiltonian $\mathcal{H}_{N,M}$ defined on a two-dimensional square lattice of N by M sites no longer possesses the aforementioned symmetry under rotation. Also, $\mathcal{H}_{N,M}$ will turn out to be a linear combination of two mutually commuting Hermitian operators. Finally, because the transfer matrix in this case is even in θ_2 , we have to take the second logarithmic derivative and this causes our Hamiltonian to be nonlocal in the left-to-right direction.³

Our motivation for this study is the fact that it is thought that the Zamolodchikov model is in some sense a free-fermion model.⁽⁷⁾ If this is so, one might hope that the model could be solved also on a finite lattice of L by M by N sites (the solution in ref. 6 was for a lattice of $L \times \infty \times \infty$; in ref. 8 it was shown that for L or M or N equal to 2, the Zamolodchikov model is equivalent to the critical 2D free-fermion model). It is easiest to investigate this possibility in a limiting case, i.e., the Hamiltonian limit. We have, however, not been able to solve the Hamiltonian model for general N and M except for the case $N=2$ and the case $M=2$. We have succeeded in finding an invariant subspace in which $\mathcal{H}_{3,M}$ effectively reduces to a sum of local operators working on a one-dimensional spin chain of M sites, but so far this reduced model has resisted solution. In particular, we have failed to observe any “direct sum” structure in numerical calculations of the eigenvalue spectrum of $\mathcal{H}_{3,M}$ performed by Dr. M. Batchelor.

2. ZAMOLODCHIKOV MODEL

The partition function of a statistical mechanical spin model on the simple cubic lattice \mathcal{L} with only intracube interactions (so-called interactions-around-a-cube models) is given by

$$Z = \sum_{\sigma} \prod_{\text{cubes}} W(a, e, f, g, b, c, d, h) \quad (2.1)$$

³ Actually, the transfer matrix is even in auxiliary parameters K_1, \dots, K_4 , expressed in terms of $\theta_1, \theta_2, \theta_3$ in Eqs. (2.4)–(2.6).

where a, \dots, h are the eight corner spins of a cube, arranged as in Fig. 1, and $W(a, e, f, g, b, c, d, h)$ is the Boltzmann weight of the spin configuration a, \dots, h . The product is over all elementary cubes in \mathcal{L} , and the sum is over all values of all the spins. In this paper we only consider periodic boundary conditions. In that case the partition function Z can be written

$$Z = \text{Trace } T^L \quad (2.2)$$

where T is the horizontal layer-to-layer transfer matrix and L is the number of layers. The elements of T are the products of the weight functions of cubes between two adjacent layers.

The 3D Zamolodchikov model is defined as follows. Let $\theta_1, \theta_2, \theta_3$ be three arbitrary real parameters between 0 and π . It is helpful to think of $\theta_1, \theta_2, \theta_3$ as the three angles of a spherical triangle (see Fig. 2). The Boltzmann weight function for the model (apart from a nonessential overall constant and a simple gauge transformation) is then given by⁽⁶⁾

$$\begin{aligned} W(a, e, f, g, b, c, d, h) &= \frac{1}{2} \exp(K_1 ag + K_2 bf + K_3 dh + K_4 ce) \\ &\quad + \frac{1}{2} afch \exp(-K_1 ag - K_2 bf - K_3 dh - K_4 ce) \end{aligned} \quad (2.3)$$

Here

$$\begin{aligned} \tanh 2K_1 &:= -e^{ia_3} T_1 T_2, & \tanh 2K_2 &:= -ie^{ia_3} T_2 / T_1 \\ \tanh 2K_3 &:= -e^{-ia_3} T_1 T_2, & \tanh 2K_4 &:= ie^{-ia_3} T_2 / T_1 \end{aligned} \quad (2.4)$$

where

$$T_1 := [\tan(\theta_1/2)]^{1/2}, \quad T_2 := [\tan(\theta_2/2)]^{1/2} \quad (2.5)$$

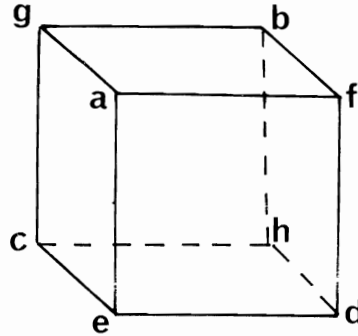

Fig. 1. Arrangement of the spins a, \dots, h on the corner sites of an elementary cube of the simple cubic lattice \mathcal{L} .

and the side of the spherical triangle a_3 (see Fig. 2) is given by⁽⁹⁾

$$\cos a_3 = \frac{\cos \theta_3 + \cos \theta_1 \cos \theta_2}{\sin \theta_1 \sin \theta_2} \quad (2.6)$$

The spins a, \dots, h each take the values $+1$ and -1 . The function $W(a, \dots, h)$ has several symmetries. In particular, it is unchanged by negating all the spins on one face in Fig. 1 (e.g., a, f, b, g). Further, negating a, b, c, d or e, f, g, h changes W at most by a sign. Clearly the transfer matrix T is a function of $\theta_1, \theta_2, \theta_3$ (as well as of the spins), so we can exhibit this dependence as

$$T \equiv T[\theta_1, \theta_2, \theta_3] \quad (2.7)$$

Zamolodchikov conjectured,^(2,3) and it was proved by Baxter,⁽⁴⁾ that any two transfer matrices $T[\theta_1, \theta_2, \theta_3], T[\theta'_1, \theta'_2, \theta'_3]$ commute provided only that $\theta'_1 = \theta_1$. This commutativity enables one to calculate the free energy of the model. Let us now see what this means in terms of the parameters K_i . First note that K_1, \dots, K_4 are not independent. From Eq. (2.4) it follows that

$$\tanh 2K_1 \tanh 2K_4 + \tanh 2K_2 \tanh 2K_3 = 0 \quad (2.8)$$

Second, two transfer matrices $T[K_1, K_2, K_3, K_4], T[K'_1, K'_2, K'_3, K'_4]$ commute provided

$$\frac{\tanh 2K_2}{\tanh 2K_1} = -\frac{\tanh 2K_4}{\tanh 2K_3} = \frac{\tanh 2K'_2}{\tanh 2K'_1} = -\frac{\tanh 2K'_4}{\tanh 2K'_3} \quad (2.9)$$

We introduce the face spins

$$\begin{aligned} \alpha &:= chbg, & \beta &:= afde \\ \gamma &:= afbg, & \delta &:= cedh \\ \varepsilon &:= bdfh, & \zeta &:= agce \end{aligned} \quad (2.10)$$

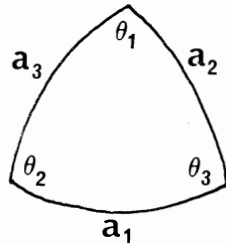

Fig. 2. The spherical triangle, with angles $\theta_1, \theta_2, \theta_3$ and sides a_1, a_2, a_3 .

Since these face spins satisfy

$$\alpha\beta = \gamma\delta = \varepsilon\zeta \quad (2.11)$$

we can replace Fig. 3 by Fig. 4. There are two types of vertices.

Vertices of type 1:

$$\alpha\gamma = 1, \quad W = \cosh(K_1 + K_2\gamma + K_3\beta\zeta + K_4\zeta) \quad (2.12a)$$

Vertices of type 2:

$$\alpha\gamma = -1, \quad W = ag \sinh(K_1 + K_2\gamma - K_3\beta\zeta + K_4\zeta) \quad (2.12b)$$

It would be convenient if the weight function W could be expressed in terms of the face spins alone. This is not quite possible. What does turn out to be feasible, however, is to express the product of the weight functions of all cubes in a left-to-right row of the lattice in terms of the face spins alone (see Fig. 5). Remembering that we have periodic boundary conditions, it follows that

$$\alpha_1\alpha_2\cdots\alpha_N = \beta_1\beta_2\cdots\beta_N = \gamma_1\gamma_2\cdots\gamma_N = 1 \quad (2.13)$$

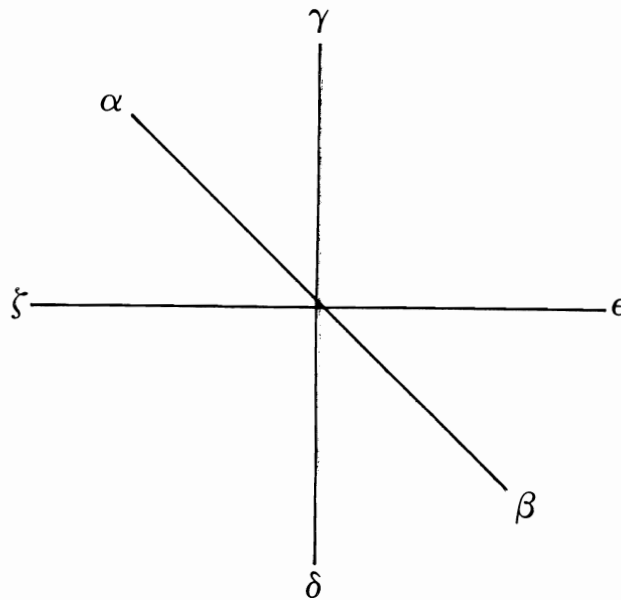

Fig. 3. A vertex with the face spins $\alpha, \beta, \gamma, \delta, \varepsilon, \zeta$.

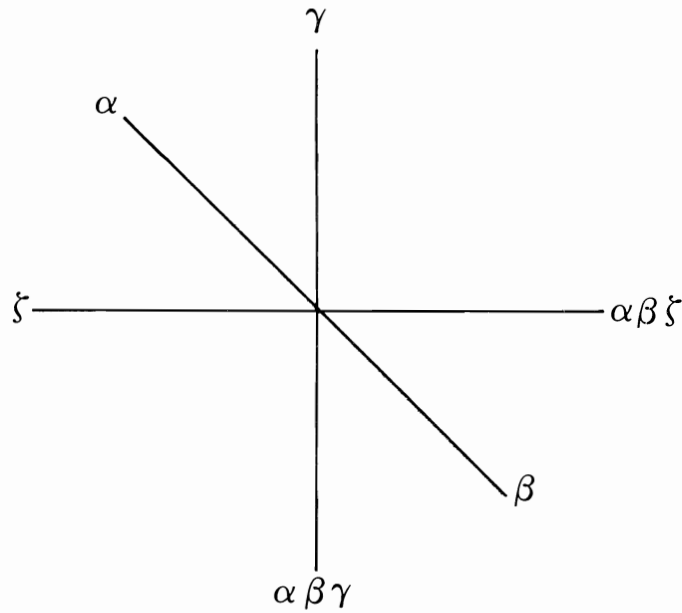

Fig. 4. The vertex of Fig. 3, after the dependence among the face spins has been eliminated.

Hence

$$\alpha_1 \gamma_1 \alpha_2 \gamma_2 \cdots \alpha_N \gamma_N = 1 \quad (2.14)$$

so we see from Eq. (2.12) that there are an even number of vertices of type 2. This has two consequences for the weight of a left-to-right row. First of all, there is an even number of factors $a_i g_i$ contributing to the weight of each such row. These can be expressed in terms of the face weights

$$a_i g_i a_j g_j = \prod \gamma_i \cdots \gamma_{j-1} \quad (2.15)$$

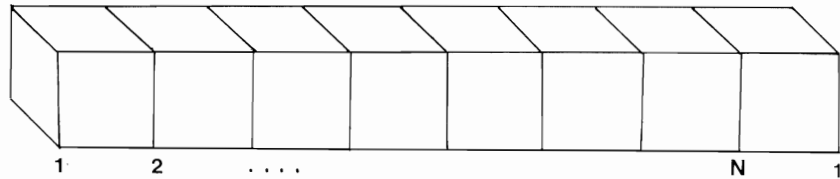

Fig. 5. A left-to-right row of the lattice.

and hence so can the weight of a left-to-right row. Second, the weight of a left-to-right row, and hence the transfer matrix and the partition function, are even under negation of all interaction parameters K_i simultaneously. From Eq. (2.13) we also see that there is an even number of vertices with $\alpha\beta = -1$.

3. THE LIMIT $K_1 \cdots K_4 \rightarrow 0$

We now want to investigate the limit $\theta_2 \rightarrow 0$ and expand about this limiting case. From Eqs. (2.4)–(2.6) it follows that in this limit $K_1, \dots, K_4 \rightarrow 0$. From Eq. (2.3) it is then clear that

$$W(a, e, f, g, b, c, d, h) \rightarrow \delta(afch, 1) \quad (3.1)$$

From Eq. (2.10) we see that this implies

$$W(\alpha, \beta, \gamma, \zeta) \rightarrow \delta(\alpha, \gamma) \quad (3.2)$$

Hence, at lowest order, all vertices are of type 1.

So, at this order, the weight of a left-to-right row of the lattice is

$$P_0 = 2 \prod_{j=1}^N \delta(\alpha_j, \gamma_j) \quad (3.3)$$

where we have performed the summation over one ζ_j , all other ζ 's being determined by the α_j and β_j .

If we want to calculate the contribution at next order to the weight of a left-to-right row, we must go to quadratic order in K because the weight function is even in K . At second order there are two sorts of terms contributing. We will consider these two different quadratic contributions one at a time.

3.1. The Quadratic Contributions of Vertices of Type 1

For a vertex at site i we get a contribution at second order [cf. Eq. (2.12a) and Fig. 6]

$$\frac{1}{2}(K_1 + K_2\alpha_i + K_3\beta_i\zeta_i + K_4\zeta_i)^2 \delta(\alpha_i, \gamma_i) \quad (3.4)$$

For the contribution to the weight of a left-to-right row we get

$$P_1 = [(K_1 + K_2\alpha_i)^2 + (K_3\beta_i + K_4)^2] \prod_{j=1}^N \delta(\alpha_j, \gamma_j) \quad (3.5)$$

where we have performed the summation over ζ_i , all other ζ 's being determined by the $\alpha_j, \beta_j, \gamma_j$.

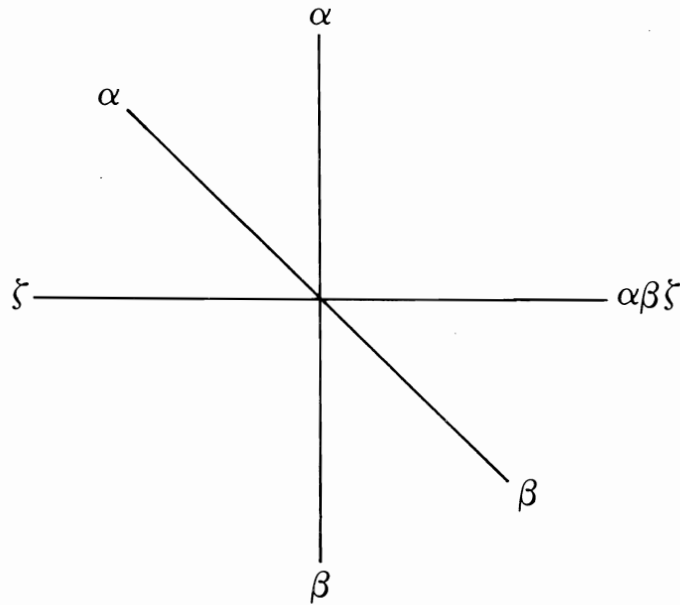

Fig. 6. A vertex of type 1 [Eq. (2.12a)].

3.2. Two Vertices of Type 2, Combining to Give a Quadratic Contribution

The linear terms of two vertices of type 2 combine to yield a quadratic contribution (remember that there is always an even number of vertices of type 2). A vertex of type 2 has the form of Fig. 7.

As an example, let us consider the case that the two vertices of type 2 are at sites 4 and 7 in a left-to-right row, respectively (see Fig. 8). From the two vertices at sites 4 and 7 we get the following contributions [cf. Eqs. (2.12) and (2.15)]

$$\begin{aligned}
 & -\alpha_4 \alpha_5 \alpha_6 (K_1 - K_2 \alpha_4 - K_3 \beta_4 \zeta_4 + K_4 \zeta_4) \\
 & \quad \times (K_1 - K_2 \alpha_7 - K_3 \zeta_4 \alpha_4 \alpha_5 \alpha_6 \beta_4 \beta_5 \beta_6 \beta_7 + K_4 \zeta_4 \alpha_4 \alpha_5 \alpha_6 \beta_4 \beta_5 \beta_6) \\
 & \quad \times \delta(\alpha_4, -\gamma_4) \delta(\alpha_7, -\gamma_7) \tag{3.6}
 \end{aligned}$$

For the contribution to the weight of a left-to-right row we get

$$\begin{aligned}
 P_1 = & -\alpha_4 \alpha_5 \alpha_6 (K_1 - K_2 \alpha_4 - K_3 \beta_4 \zeta_4 + K_4 \zeta_4) \\
 & \quad \times (K_1 - K_2 \alpha_7 - K_3 \zeta_4 \alpha_4 \alpha_5 \alpha_6 \beta_4 \beta_5 \beta_6 \beta_7 + K_4 \zeta_4 \alpha_4 \alpha_5 \alpha_6 \beta_4 \beta_5 \beta_6) \\
 & \quad \times \delta(\alpha_4, -\gamma_4) \delta(\alpha_7, -\gamma_7) \prod_{\substack{j=1 \\ \neq 4,7}}^N \delta(\alpha_j, \gamma_j) \tag{3.7}
 \end{aligned}$$

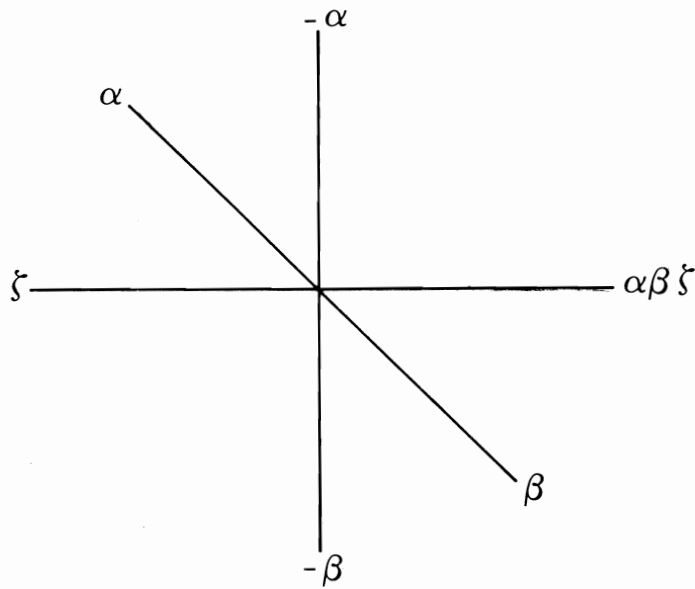

Fig. 7. A vertex of type 2 [Eq. (2.12b)].

Averaging over $\zeta_4 = \pm 1$, this becomes

$$\begin{aligned}
 & -2[\alpha_4\alpha_5\alpha_6(K_1 - K_2\alpha_4)(K_1 - K_2\alpha_7) + \beta_5\beta_6\beta_7(K_3 - K_4\beta_4) \\
 & \times (K_3 - K_4\beta_7)]\delta(\alpha_4, -\gamma_4)\delta(\alpha_7, -\gamma_7) \prod_{\substack{j=1 \\ \neq 4,7}}^N \delta(\alpha_j, \gamma_j) \quad (3.8)
 \end{aligned}$$

4. HAMILTONIAN LIMIT OF THE TRANSFER MATRIX

We will now consider what happens to an entire horizontal layer of the lattice. In Figs. 9 and 10 we have sketched schematically the case when

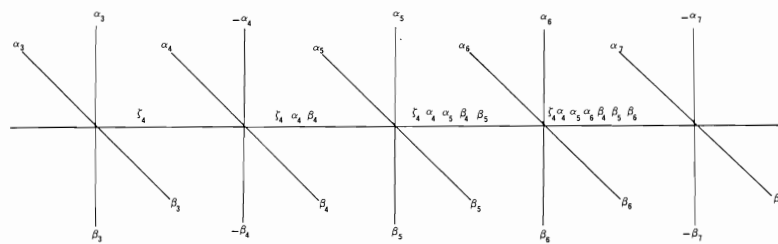

Fig. 8. A left-to-right row of the lattice, with two vertices of type 2, at sites 4 and 7, respectively.

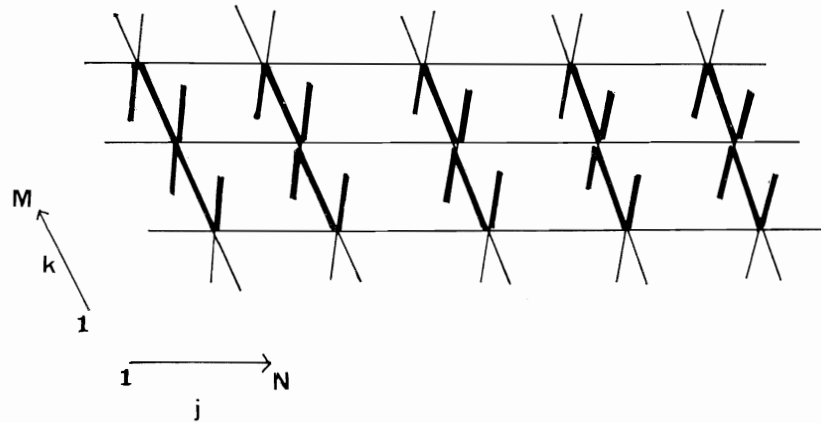

Fig. 9. A horizontal layer of the lattice with all vertices being of type 1.

all vertices are of type 1 and the case where two vertices in one left-to-right row are of type 2, respectively.

The transfer matrix for the general case can be expanded in powers of the interaction parameters K_i . Symbolically, we can write this expansion as follows:

$$T = T_0 + T_1(K^2) + O(K^4) \quad (4.1)$$

The zeroth-order term T_0 in Eq. (4.1) is given by the lowest order contribution of configurations which only have vertices of type 1 (Fig. 9).

$$T_0(\underline{\delta}_1, \underline{\delta}_2, \dots | \underline{\gamma}_1, \underline{\gamma}_2, \dots) = \prod_{k=1}^M \delta(\underline{\gamma}_k, \underline{\delta}_{k+1}) \quad (4.2)$$

{ T_0 is equal to $T[\theta_1, 0, \theta_3]$ of Eq. (2.7)}.

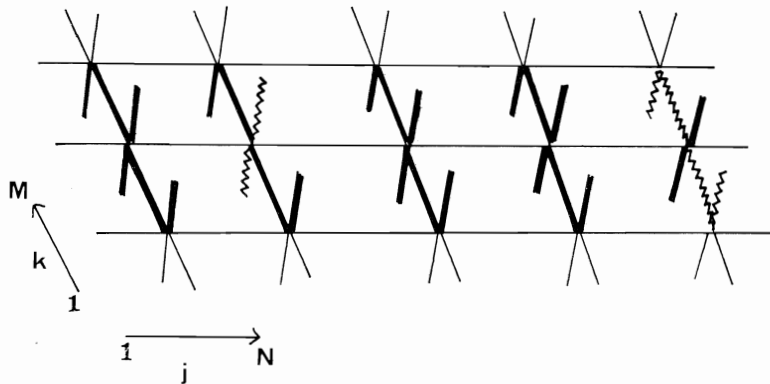

Fig. 10. A horizontal layer of the lattice with two vertices in one left-to-right row of type 2, all other vertices being of type 1.

Equation (4.1) can be rewritten

$$T_0^{-1}T = \mathbb{1} + T_0^{-1}T_1(K^2) + O(K^4) \tag{4.3}$$

and we are interested in calculating the quadratic term in this equation

$$\begin{aligned} \mathcal{H}_{N,M} := T_0^{-1}T &= \sum_{k=1}^M \sum_{j=1}^N \frac{1}{2} (K_1 + K_2 s_{j,k})^2 + \frac{1}{2} (K_3 + K_4 s_{j,k-1})^2 \\ &+ \sum_{k=1}^M \sum_{1 \leq i < j \leq N} c_{i,k} c_{j,k} [s_{i,k} s_{i+1,k} \cdots s_{j-1,k} \\ &\times (K_1 + K_2 s_{i,k})(K_1 + K_2 s_{j,k}) \\ &+ s_{i+1,k-1} \cdots s_{j,k-1} (K_3 + K_4 s_{i,k-1}) \\ &\times (K_3 + K_4 s_{j,k-1})] c_{i,k-1} c_{j,k-1} \end{aligned} \tag{4.4}$$

where the operators $s_{j,k}$ and $c_{j,k}$ (also known as the Pauli spin operators $\sigma_{j,k}^z$ and $\sigma_{j,k}^x$) are defined by (ref. 1, p. 83)

$$\begin{aligned} (s_{j,k})_{\underline{\delta}, \underline{\gamma}} &:= \gamma_{j,k} \prod_{n=1}^N \prod_{m=1}^M \delta(\gamma_{n,m}, \delta_{n,m}) \\ (c_{j,k})_{\underline{\delta}, \underline{\gamma}} &:= \delta(\gamma_{j,k}, -\delta_{j,k}) \prod_{\substack{n=1 \\ (n,m)}}^N \prod_{\substack{m=1 \\ \neq (j,k)}}^M \delta(\lambda_{n,m}, \delta_{n,m}) \end{aligned} \tag{4.5}$$

Each term in the operator $\mathcal{H}_{N,M}$ commutes with

$$R_k := s_{1,k} s_{2,k} \cdots s_{N,k}, \quad k = 1, \dots, M \tag{4.6}$$

and with

$$S_j := s_{j,1} s_{j,2} \cdots s_{j,M}, \quad j = 1, \dots, N \tag{4.7}$$

Note that not all these symmetries are independent,

$$\prod_{k=1}^M R_k = \prod_{j=1}^N S_j \tag{4.8}$$

For the Zamolodchikov model with periodic boundary conditions we have

$$R_k = S_j = \mathbb{1}, \quad \forall j, k \tag{4.9}$$

Omitting an additive scalar multiple of the identity, we can rewrite the Hamiltonian $\mathcal{H}_{N,M}$ as

$$\begin{aligned} \mathcal{H}_{N,M} = & \sum_{k=1}^M \sum_{j=1}^N (K_1 K_2 + K_3 K_4) s_{j,k} \\ & + \sum_{k=1}^M \sum_{1 \leq i < j \leq N} c_{i,k} c_{j,k} [s_{i,k} \cdots s_{j-1,k} (K_1 + K_2 s_{i,k}) (K_1 + K_2 s_{j,k}) \\ & + s_{i+1,k-1} \cdots s_{j,k-1} (K_3 + K_4 s_{i,k-1}) (K_3 + K_4 s_{j,k-1})] c_{i,k-1} c_{j,k-1} \end{aligned} \quad (4.10)$$

This Hamiltonian appears not to be translation invariant. This invariance is restored if we impose (4.9). From Eq. (2.8) it follows that at this order the interaction parameters satisfy

$$K_1 K_4 + K_2 K_3 = 0 \quad (4.11)$$

Defining

$$x := \frac{K_2}{K_1} = -\frac{K_4}{K_3} \quad (4.12)$$

we can write the Hamiltonian as

$$\begin{aligned} H_{N,M} = & \sum_{k=1}^M \sum_{j=1}^N x (K_1^2 - K_3^2) s_{j,k} \\ & + \sum_{k=1}^M \sum_{1 \leq i < j \leq N} c_{i,k} c_{j,k} c_{i,k-1} c_{j,k-1} \\ & \times [K_1^2 s_{i,k} \cdots s_{j-1,k} (1 + x s_{i,k}) (1 + x s_{j,k}) \\ & - K_3^2 s_{i+1,k-1} \cdots s_{j,k-1} (1 + x s_{i,k-1}) (1 + x s_{j,k-1})] \end{aligned} \quad (4.13)$$

Hence we can write

$$H_{N,M} = -iK_1^2 X_{N,M} + iK_3^2 Y_{N,M} \quad (4.14)$$

where

$$\begin{aligned} X_{N,M} & := iA_{N,M} + ixB_{N,M} + ix^2 C_{N,M} \\ Y_{N,M} & := iD_{N,M} + ixE_{N,M} + ix^2 F_{N,M} \end{aligned} \quad (4.15)$$

and $A_{N,M}, \dots, F_{N,M}$ are independent of x and are given by

$$A_{N,M} := \sum_{k=1}^M \sum_{1 \leq i < j \leq N} c_{i,k} c_{j,k} c_{1,k-1} c_{j,k-1} s_{i,k} \cdots s_{j-1,k} \quad (4.16a)$$

$$B_{N,M} := \sum_{k=1}^M \sum_{j=1}^N s_{j,k} + \sum_{k=1}^M \sum_{1 \leq i < j \leq N} c_{i,k} c_{j,k} c_{i,k-1} c_{j,k-1} \times s_{i,k} \cdots s_{j-1,k} (s_{i,k} + s_{j,k}) \quad (4.16b)$$

$$C_{N,M} := \sum_{k=1}^M \sum_{1 \leq i < j \leq N} c_{i,k} c_{j,k} c_{i,k-1} c_{j,k-1} s_{i+1,k} \cdots s_{j,k} \quad (4.16c)$$

$$D_{N,M} := \sum_{k=1}^M \sum_{1 \leq i < j \leq N} c_{i,k} c_{j,k} c_{i,k-1} c_{j,k-1} s_{i+1,k-1} \cdots s_{j,k-1} \quad (4.16d)$$

$$E_{N,M} := \sum_{k=1}^M \sum_{j=1}^N s_{j,k} + \sum_{k=1}^M \sum_{1 \leq i < j \leq N} c_{i,k} c_{j,k} c_{i,k-1} c_{j,k-1} \times s_{i+1,k-1} \cdots s_{j,k-1} (s_{i,k-1} + s_{j,k-1}) \quad (4.16e)$$

$$F_{N,M} := \sum_{k=1}^M \sum_{1 \leq i < j \leq N} c_{i,k} c_{j,k} c_{i,k-1} c_{j,k-1} s_{i,k-1} \cdots s_{j-1,k-1} \quad (4.16f)$$

It is easy to check that if x is purely imaginary [this is the case if K_1, \dots, K_4 are defined by (2.4)], then $X_{N,M}$ and $Y_{N,M}$ are Hermitian. Moreover, from the discussion in Section 2 it follows that if we take the limit $K_1, \dots, K_4 \rightarrow 0$ such that the ratio x defined in Eq. (4.12) remains finite, then sufficient conditions for the operators $X_{N,M}(x)$ and $Y_{N,M}(x')$ to commute are that (i) $x = x'$, (ii) $R_k = \mathbb{1}$ for all k , and (iii) $S_j = \mathbb{1}$ for all j . We will now sketch a proof, using only the conditions (i) and (ii), i.e., we will prove that

$$[A_{N,M}, D_{N,M}]_- = 0 \quad (4.17a)$$

$$[A_{N,M}, E_{N,M}]_- + [B_{N,M}, D_{N,M}]_- = 0 \quad (4.17b)$$

$$[A_{N,M}, F_{N,M}]_- + [B_{N,M}, E_{N,M}]_- + [C_{N,M}, D_{N,M}]_- = 0 \quad (4.17c)$$

$$[B_{N,M}, F_{N,M}]_- + [C_{N,M}, E_{N,M}]_- = 0 \quad (4.17d)$$

$$[C_{N,M}, F_{N,M}]_- = 0 \quad (4.17e)$$

The first and last of these equations are easy to prove because actually each term of $A_{N,M}$ commutes with each term of $D_{N,M}$ and likewise each term of $C_{N,M}$ commutes with each term of $F_{N,M}$. To prove the remaining equations we will make use of two symmetry operations, the vertical reflection V and the inversion I , defined by

$$\begin{aligned} V(s_{j,k}) &:= s_{N+1-j,k}, & V(c_{j,k}) &:= c_{N+1-j,k} \\ I(s_{j,k}) &:= s_{N+1-j, M+1-k}, & I(c_{j,k}) &:= c_{N+1-j, M+1-k} \end{aligned} \quad (4.18)$$

The operators A, \dots, F (dropping the subscripts N and M) then have the following symmetry properties:

$$\begin{aligned} V(A) = C, \quad V(B) = B, \quad V(D) = F, \quad V(E) = E \\ I(A) = D, \quad I(B) = E, \quad I(C) = F \end{aligned} \quad (4.19)$$

These relations imply that (4.17b) and (4.17c) are equivalent to

$$\begin{aligned} I([A, E]_-) &= [A, E]_- \\ I(2[A, F]_- + [B, E]_-) &= 2[A, F]_- + [B, E]_- \end{aligned} \quad (4.20)$$

i.e., $[A, E]_-$ and $2[A, F]_- + [B, E]_-$ should be invariant under the inversion operation. We have verified this by explicit bookkeeping. Equation (4.17d) then follows from Eq. (4.17b) by applying the vertical reflection operation. This completes the proof of (4.17), yielding an independent check of our workings and those of ref. 4.

For $x = \pm 1$ the operator $1 + xs$ is a projection operator and we see that in that case $\mathcal{H}_{N,M}$ has a large number of eigenvectors that are annihilated by each term in the second double sum in Eq. (4.13)

In the next three sections the Hamiltonian $\mathcal{H}_{N,M}$ given by Eq. (4.13) will be discussed for the special case $M = 2$, and the cases $N = 2$ and $N = 3$, respectively.

5. $M = 2$: THE TWO-ROW CASE

In the case $M = 2$ we restrict ourselves to the subspace where

$$s_{j,1} s_{j,2} = \mathbb{1}, \quad \forall j \quad (5.1)$$

[with this choice $\mathcal{H}_{N,2}$ corresponds to the Zamolodchikov model with periodic boundary conditions; cf. Eq. (4.9)], i.e., we consider the subspace spanned by

$$A_j := \begin{bmatrix} 1 \\ 1 \end{bmatrix} \rangle \quad \text{and} \quad B_j := \begin{bmatrix} -1 \\ -1 \end{bmatrix} \rangle \quad (5.2)$$

It is easy to verify that

$$c_{j,1} c_{j,2} A_j = B_j, \quad c_{j,1} c_{j,2} B_j = A_j \quad (5.3)$$

so a simpler representation is given by

$$\begin{aligned} s_{j,1} = s_j; \quad s_{j,2} = s_j \\ c_{j,1} c_{j,2} = c_j \\ A_j = |1\rangle; \quad B_j = |-1\rangle \end{aligned} \quad (5.4)$$

Using these definitions, we can write the Hamiltonian $\mathcal{H}_{N,2}$ as

$$\begin{aligned} \mathcal{H}_{N,2} = & 2x(K_1^2 - K_3^2) \sum_{j=1}^N s_j \\ & + 2 \sum_{1 \leq i < j \leq N} c_i c_j s_{i+1} \cdots s_{j-1} \\ & \times [x(K_1^2 - K_3^2)(1 + s_i s_j) + (K_1^2 - x^2 K_3^2) s_i + (x^2 K_1^2 - K_3^2) s_j] \end{aligned} \quad (5.5)$$

This Hamiltonian can be expressed in terms of fermion operators as follows.

Define

$$\begin{aligned} P_k & := \prod_{j=1}^k (-s_j) & d_k & := ic_k s_k \\ \sigma_k^\pm & := \frac{1}{2}(c_k \pm id_k), & f_k^\pm & := P_{k-1} \sigma_k^\pm \end{aligned} \quad (5.6)$$

Then the f_k^\pm satisfy fermion anticommutation relations

$$[f_j^-, f_k^+]_+ = \delta(j, k); \quad [f_j^-, f_k^-]_+ = [f_j^+, f_k^+]_+ = 0 \quad (5.7)$$

In terms of these fermion operators, the Hamiltonian becomes

$$\begin{aligned} \mathcal{H}_{N,2} = & 2x(K_1^2 - K_3^2) \sum_{j=1}^N (f_j^+ f_j^- - f_j^- f_j^+) \\ & + 2 \sum_{1 \leq i < j \leq N} (-1)^{i-j} [2x(K_1^2 - K_3^2)(f_i^- f_j^- - f_i^+ f_j^+) \\ & + (K_1^2 - x^2 K_3^2)(f_i^+ + f_i^-)(f_j^+ + f_j^-) - (x^2 K_1^2 - K_3^2)(f_i^+ - f_i^-)(f_j^- - f_j^+)] \end{aligned} \quad (5.8)$$

This Hamiltonian is quadratic in fermion operators and can be diagonalized (see, e.g., ref. 10). For $M=2$ the Zamolodchikov model is equivalent to the critical 2D free-fermion model⁽⁸⁾ (cf. refs. 11 and 12).

6. $N=2$: THE TWO-COLUMN CASE

For $N=2$ we restrict ourselves to the subspace where

$$s_{1,k} s_{2,k} = 1, \quad \forall k \quad (6.1)$$

(with this choice $\mathcal{H}_{2,M}$ corresponds again to the Zamolodchikov model with periodic boundary conditions), i.e., we consider the space spanned by

$$A_k := |11\rangle \quad \text{and} \quad B_k := |-1 -1\rangle, \quad \forall k \quad (6.2)$$

It is easy to verify that

$$\begin{aligned} s_{1,k}A_k = s_{2,k}A_k = A_k, & \quad s_{1,k}B_k = s_{2,k}B_k = -B_k \\ c_{1,k}c_{2,k}A_k = B_k, & \quad c_{1,k}c_{2,k}B_k = A_k \end{aligned} \quad (6.3)$$

Equation (6.3) can be represented more simply by taking

$$\begin{aligned} s_{2,k} &= s_{1,k} \\ c_{1,k}c_{2,k} &= c_{1,k} \\ A_k &= |1\rangle, \quad B_k = |-1\rangle \end{aligned} \quad (6.4)$$

Using these definitions, we can express the Hamiltonian $\mathcal{H}_{2,M}$ by (omitting the index 1 on the operators)

$$\mathcal{H}_{2,M} = \sum_{k=1}^M 2x(K_1^2 - K_3^2) s_k + c_k c_{k-1} [K_1^2 s_k (1 + x s_k)^2 - K_3^2 s_{k-1} (1 + x s_{k-1})^2] \quad (6.5)$$

Using

$$c_k s_k = -i d_k \quad (6.6)$$

we find that this becomes

$$\begin{aligned} \mathcal{H}_{2,M} &= \sum_{k=1}^M 2x(K_1^2 - K_3^2)(s_k + c_{k-1}c_k) \\ &\quad - iK_1^2(1+x^2)c_{k-1}d_k + iK_3^2(1+x^2)d_{k-1}c_k \end{aligned} \quad (6.7)$$

This Hamiltonian is again quadratic in fermion operators (of XY type) and solved. Note that $\mathcal{H}_{2,M}$ commutes with

$$S := \prod_{k=1}^M s_k \quad (6.8)$$

For $N=2$ the Zamolodchikov model is again equivalent to the critical 2D free-fermion model.⁽⁸⁾

7. $N=3$: THE THREE-COLUMN CASE

For $N=3$ we will consider here only the special case $x=0$, i.e., $K_2 = K_4 = 0$. Then the Hamiltonian $\mathcal{H}_{3,M}$ can be written

$$\begin{aligned} \mathcal{H}_{3,M} &= -iK_1^2 X_{3,M} + iK_3^2 Y_{3,M} \\ &= \sum_{k=1}^M -iK_1^2 [X_k^1 + X_k^2 + X_k^3] + iK_3^2 [Y_k^1 + Y_k^2 + Y_k^3] \end{aligned} \quad (7.1)$$

where

$$\begin{aligned}
 X_k^1 &:= ic_{2,k}c_{3,k}c_{2,k-1}c_{3,k-1}s_{2,k}, \\
 Y_k^1 &:= ic_{2,k}c_{3,k}c_{2,k-1}c_{3,k-1}s_{3,k-1} \\
 X_k^2 &:= ic_{1,k}c_{2,k}c_{1,k-1}c_{2,k-1}s_{1,k}, \\
 Y_k^2 &:= ic_{1,k}c_{2,k}c_{1,k-1}c_{2,k-1}s_{2,k-1} \\
 X_k^3 &:= ic_{1,k}c_{3,k}c_{1,k-1}c_{3,k-1}s_{1,k}s_{2,k}, \\
 Y_k^3 &:= ic_{1,k}c_{3,k}c_{1,k-1}c_{3,k-1}s_{2,k-1}s_{3,k-1}
 \end{aligned} \tag{7.2}$$

The X_k^α satisfy the following commutation and anticommutation relations:

$$\begin{aligned}
 [X_k^\alpha, X_k^\beta]_+ &= 2\delta(\alpha, \beta) \\
 [X_k^\alpha, X_{k+1}^\alpha]_+ &= 0, \quad [X_k^\alpha, X_{k+1}^{\alpha+1}]_+ = 0, \quad [X_k^\alpha, X_{k+1}^{\alpha+2}]_- = 0 \\
 [X_j^\alpha, X_k^\beta]_- &= 0, \quad |j-k| \geq 2
 \end{aligned} \tag{7.3}$$

(here and below α and β should be interpreted modulo 3). The Y_k^α satisfy identical relations and commute with the X_j^β ,

$$[X_j^\beta, Y_k^\alpha] = 0, \quad \forall \alpha, \beta, j, k \tag{7.4}$$

We now consider an abstract Hamiltonian, defined by (7.1), (7.4), and by (7.3) and the analogous relations for the Y_k^α . Our previous Hamiltonian is then a specific representation of these relations, given by (7.2). Using (7.3) and taking periodic boundary conditions for X and Y , i.e.,

$$X_{M+1}^\alpha = X_1^\alpha, \quad Y_{M+1}^\alpha = Y_1^\alpha \tag{7.5}$$

it follows that such an abstract Hamiltonian (7.1) commutes with the following operators:

$$\begin{aligned}
 C_k^1(X) &:= X_k^1 X_k^2 X_k^3 \\
 C^2(X) &:= \prod_{k=1}^M X_k^1 \\
 C^3(X) &:= \prod_{k=1}^M X_k^2 \\
 C^4(X) &:= \sum_{k=1}^M (X_k^1 X_{k+1}^1 + X_k^2 X_{k+1}^2 + X_k^3 X_{k+1}^3 \\
 &\quad + X_k^1 X_{k+1}^2 + X_k^2 X_{k+1}^3 + X_k^3 X_{k+1}^1)
 \end{aligned} \tag{7.6}$$

and if M is a multiple of three, $\mathcal{H}_{3,M}$ also commutes with

$$\begin{aligned} C^5(X) &:= \prod_{k=1}^{M/3} X_{3k}^2 X_{3k+1}^1 \\ C^6(X) &:= \prod_{k=1}^{M/3} X_{3k+1}^2 X_{3k+2}^1 \end{aligned} \quad (7.7)$$

Finally, $\mathcal{H}_{3,M}$ of course also commutes with $C_k^1(Y)$, $C^2(Y)$, $C^3(Y)$, and $C^4(Y)$, and, if M is a multiple of three, with $C^5(Y)$ and $C^6(Y)$, where all these operators are obtained by replacing X by Y in the above definitions.

Since $X_{3,M}$ and $Y_{3,M}$ commute, we will henceforth focus on $X_{3,M}$. It is convenient to define new operators Z_k^α by

$$Z_k^\alpha := X_k^{\alpha+2k} \quad (7.8)$$

These new operators then satisfy

$$\begin{aligned} [Z_k^\alpha, Z_k^\beta]_+ &= 2\delta(\alpha, \beta) \\ [Z_k^\alpha, Z_{k+1}^\alpha]_- &= 0, \quad [Z_k^\alpha, Z_{k+1}^{\alpha+1}]_+ = 0, \quad [Z_k^\alpha, Z_{k+1}^{\alpha+2}]_+ = 0 \\ [Z_j^\alpha, Z_k^\beta]_- &= 0, \quad |j-k| \geq 2 \end{aligned} \quad (7.9)$$

Note that if M is not a multiple of three, the transformation (7.8) affects the boundary conditions. Periodic boundary conditions, e.g., are related by

$$\begin{aligned} X_{M+1}^\alpha &= X_1^\alpha \leftrightarrow Z_{M+1}^\alpha = Z_1^{\alpha+2M} \\ Z_{M+1}^\alpha &= Z_1^\alpha \leftrightarrow X_{M+1}^\alpha = X_1^{\alpha-2M} \end{aligned} \quad (7.10)$$

We are interested in an operator defined by

$$X_{3,M} = \sum_k (Z_k^1 + Z_k^2 + Z_k^3) \quad (7.11)$$

and by the relations (7.9). Assuming periodic boundary conditions for the Z 's, such an operator commutes with

$$\begin{aligned} \tilde{C}_k^1(Z) &:= Z_k^1 Z_k^2 Z_k^3 \\ \tilde{C}^4(Z) &:= \sum_k (Z_k^1 Z_{k+1}^2 + Z_k^2 Z_{k+1}^1 + Z_k^2 Z_{k+1}^3 \\ &\quad + Z_k^3 Z_{k+1}^2 + Z_k^3 Z_{k+1}^1 + Z_k^1 Z_{k+1}^3) \end{aligned} \quad (7.12)$$

and, if M is a multiple of 3, also with

$$\begin{aligned}
 \tilde{C}^2(Z) &= \prod_k Z_{3k}^1 Z_{3k+1}^1 \\
 \tilde{C}^3(Z) &= \prod_k Z_{3k+1}^1 Z_{3k+2}^1 \\
 \tilde{C}^5(Z) &= \prod_k Z_{3k}^2 Z_{3k+1}^2 \\
 \tilde{C}^6(Z) &= \prod_k Z_{3k+1}^2 Z_{3k+2}^2
 \end{aligned} \tag{7.13}$$

Of course, a representation of the commutation and anticommutation relations (7.9) can be derived from (7.2), using (7.8). A simpler representation, however, is found in the following way. Since all Z_k^1 commute, we can define ψ to be their common eigenvector such that

$$Z_k^1 \psi = \psi, \quad \forall k \tag{7.14}$$

We will consider the subspace generated by this vector. This subspace is spanned by the basis vectors

$$\psi_{\lambda_1, \dots, \lambda_M} = \prod_{j=1}^M (Z_j^2)^{(1-\lambda_j)/2} \psi \tag{7.15}$$

where

$$\lambda_k = \pm 1$$

Using (7.9), it is easy to check that

$$\begin{aligned}
 Z_k^1 \psi_{\lambda_1, \dots, \lambda_M} &= \lambda_{k-1} \lambda_k \lambda_{k+1} \psi_{\lambda_1, \dots, \lambda_M} \\
 Z_k^2 \psi_{\lambda_1, \dots, \lambda_k, \dots, \lambda_M} &= \psi_{\lambda_1, \dots, -\lambda_k, \dots, \lambda_M}
 \end{aligned} \tag{7.16}$$

and, taking $Z_k^3 = iZ_k^1 Z_k^2$,

$$Z_k^3 \psi_{\lambda_1, \dots, \lambda_k, \dots, \lambda_M} = i\lambda_{k-1} \lambda_k \lambda_{k+1} \psi_{\lambda_1, \dots, -\lambda_k, \dots, \lambda_M} \tag{7.17}$$

A representation of these relations is given by

$$\begin{aligned}
 Z_k^1 &= s_{k-1} s_k s_{k+1} \\
 Z_k^2 &= c_k \\
 Z_k^3 &= -s_{k-1} d_k s_{k+1}
 \end{aligned} \tag{7.18}$$

Hence $X_{3,M}$ can be represented by

$$X_{3,M} = \sum_{k=1}^M (s_{k-1}s_k s_{k+1} + c_k - s_{k-1}d_k s_{k+1}) \quad (7.19)$$

Although $X_{3,M}$ describes a limiting case of the exactly solved Zamolodchikov model, we have so far not succeeded in obtaining its eigenvalues for finite M . If this is a free-fermion model, one would expect to see some "direct sum" structure similar to the cases $N=2$ and $M=2$. In fact, we have failed to observe any such structure either algebraically or in numerical calculations performed by Dr. M. Batchelor.

NOTE ADDED IN PROOF

Defining $Z^i := \sum_k Z_k^i$ ($i = 1, 2, 3$), and using (7.9) and periodic boundary conditions, one can prove $[Z^i, [Z^i, [Z^i, [Z^i, Z^j]]]] = 40[Z^i, [Z^i, Z^j]] - 144 Z^j$ ($i=1, 2, 3; j=1, 2, 3; i \neq j$). These relations are reminiscent of the Dolan-Grady relations (L. Dolan and M. Grady, *Phys. Rev.* **D25**:1587 (1982)).

ACKNOWLEDGMENTS

G.R.W.Q. thanks Brian Davies and Paul Pearce for useful discussions.

REFERENCES

1. T. J. Baxter, *Exactly Solved Models in Statistical Mechanics* (Academic, London, 1982).
2. A. B. Zamolodchikov, *Zh. Eksp. Teor. Fiz.* **79**:641 (1980); *Sov. Phys. JETP* **52**:325 (1980).
3. A. B. Zamolodchikov, *Commun. Math. Phys.* **79**:489 (1981).
4. R. J. Baxter, *Commun. Math. Phys.* **88**:185 (1983).
5. R. J. Baxter, *Phys. Rev. Lett.* **53**:1795 (1984).
6. R. J. Baxter, *Physica* **18D**:321 (1986).
7. A. B. Zamolodchikov, private communication.
8. R. J. Baxter and P. J. Forrester, *J. Phys. A* **18**:1483 (1985).
9. Vieta, *Variorum de rebus mathematicis responsorum*, Vol. 8 (1595).
10. J.-P. Blaizot and G. Ripka, *Quantum Theory of Finite Systems* (MIT Press, Cambridge, Massachusetts, 1986).
11. S. Krinsky, *Phys. Lett.* **39A**:169 (1972).
12. B. U. Felderhof, *Physica* **66**:279 (1973).